

28" New Look Overhead Video Display Support Specifications

NOTE: All of these documents are in PDF format located at www.steltronicusa.com

Using the preferred method of support, the overhead video display unit is suspended from wood beams or 3" black metal pipe (NO ANGLE IRON), which are bridged between the roof trusses. The customer is responsible for supplying, installing, and maintaining the proper position of these beams or pipe (reference figures below) and for having certification from an architect or structural engineer that the method of support will be capable of supporting 120 pounds of actual/static weight per video monitor (240 pounds per pair of bowling lanes).

Steltronic will provide the 6 foot long metal bars that will be supported above your ceiling.



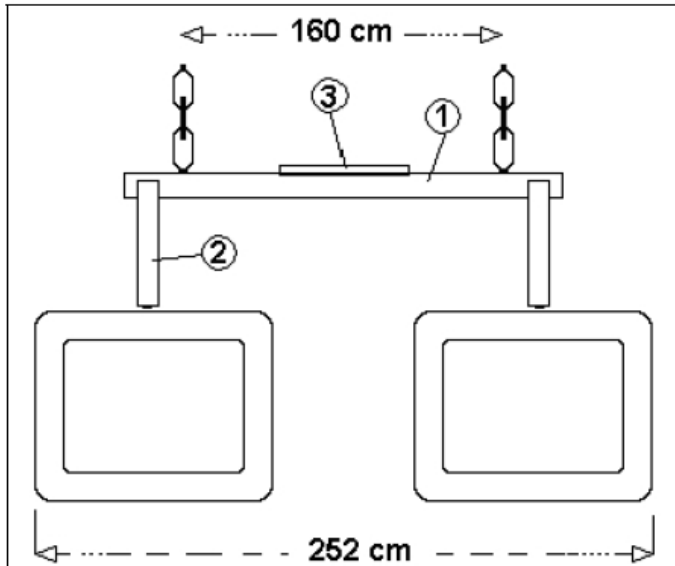

Fig. 17: New Look 28" monitors hung in the center of the lane. The horizontal bar (1) MEC-Y-MW0053C has a shelf to support the lane computer (3), The monitors are hung using the vertical bars (2). The entire structure is hung using chains. It is possible to hang WinVision28" monitors with this same mechanism. Without the center panel usually used with this monitor style.

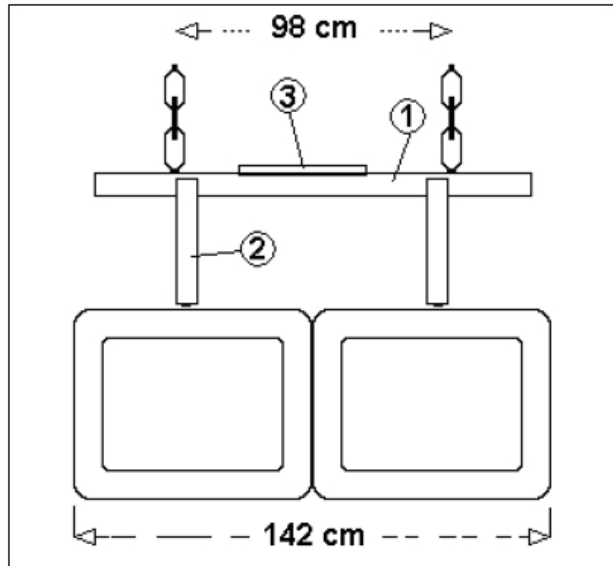

Fig. 18: New Look 28" monitors hung next to one another. The horizontal bar (1) MEC-Y-MW0053C has a shelf to support the lane computer (3), the monitors are hung using the vertical bars (2) The entire structure is hung using chains.

Prior to installation of any monitor, US Steltronic requires your structural engineer to sign the certificate below.

US Steltronic and its certified installers may not start to install any monitor until this certificate is properly filled out and stamped by your engineer.

It is the responsibility of the building contractor or current bowling center owner to obtain the services of a registered structural engineer or architect to determine that the requirements stated in this document can be obtained. Certification must be based on an investigation of the actual structure or drawings specifying the overhead construction supporting the curtain wall and U.S. Steltronic overhead monitors.

Shipment of Automatic Scoring Equipment will not be authorized prior to U.S. Steltronic receipt of this completed document.

"I have investigated the structures or the drawings for the structures at:

_____ Lanes

located at: _____

City: _____ State _____ Zip _____

and certify:

"There is a device in place that will support the weight of a 240 pound static load per pair of lanes for _____ (28" CRT Overhead Monitor Assemblies)"

"Also, there is a device in place that will support an additional load of 120 pounds for each additional single monitor assembly, if ordered (qty: _____). (Known as triple monitors per pair)

These units are located over the approach in the ball return area."

"The Curtain wall will support a load of 6 pounds (11 kg) over each pair of pinsetters."

Signed: _____ P.E. # _____

Address: _____

City: _____ State _____

Send to: U.S. Steltronic, LLC
5480 Schaefer Avenue
Chino, CA 91710

P.E. Seal



Certification and Release of US Steltronic, LLC by Proprietor

I, _____, as the proprietor or as duly-authorized representative of the proprietor, certify to US Steltronic, LLC that:

1. The proprietor has obtained the above structure certification for the proprietor's own benefit; and
2. The proprietor is not relying upon US Steltronic, LLC that the roof structure described in the structure certification will support the overhead video display units selected by the proprietor and installed by US Steltronic, LLC.

In consideration for US Steltronic, agreement to install the overhead video display units, and by signing below, proprietor for proprietor's own self and for proprietor's heirs, successors, assigns, employees, agents, representatives, insurers, contractors, subcontractors, and their spouses and relatives ("Proprietor Group"), releases and agrees to indemnify US Steltronic, LLC, it's officers, directors, employees, parent companies, subsidiaries, and affiliated companies, insurers, agents, contractors, subcontractors, from all claims, demands, actions, causes of action, or their functional equivalent, that any member of the Proprietor Group may have subsequently accrue to a member of the Proprietor Group arising out of or connected with, directly or indirectly, the inability of the roof structure described in the above structure certification to support the overhead video display units installed by US Steltronic, LLC in accordance with the support specifications on the reverse of this sheet.

Printed or typed name of proprietor

Signature

Title

Date

US Steltronic 28" Overhead Electrical Requirements

1. We require a duplex and single receptacle (3 outlets) for each pair of lanes. THREE OUTLETS TOTAL PER PAIR OF LANES.
2. Each CRT monitor circuit needs to be rated at 2 AMPS per monitor.
3. Each lane computer circuit should be rated at 2 AMPS per lane computer
4. The electrician should install a 20-amp circuit for each 6 lanes of overhead monitors.
5. An additional circuit (**always on**) should be placed at the middle of the center. For example, if you have a 24 lane center an additional circuit is required for the network hub/switch and should be placed over lane 11-12 in the vicinity of the monitors hanging near the foul line. (**Always on and separate from the circuits described above in bullet #3**)
6. The electrician should install a 10 amp circuit for the network hub. Every night when closing, the overhead monitors & lane computers (electrical circuits) should be turned off. Since it is not practical to use circuit breakers as an on/off switch, we recommend that the electrician put in some type of switching device to turn off these circuits. This can be done based on the electrician's suggestions:
 - Install a lighting contactor with a remote key switch at the desk. (Preferred method)
 - Install a standard light switch very close to the front desk shoe counter.
7. Place the electrical outlets (FLUSH MOUNTED IN THE CEILING TILE or DRYWALL) as close as possible to the location of where the monitors will be placed.
8. All electrical for this automatic scoring needs to be on a DEDICATED INSULATED ISOLATED GROUND CIRCUIT, and lightning arrestors should be installed on the new electrical panel.

Front Desk & other Scoring Items

1. The front desk requires a 10 AMP minimum circuit for each computer, on the dedicated isolated ground panel
2. Every additional computer requires a 10 AMP minimum circuit, on the dedicated isolated ground panel
3. The photo strike kiosk (if purchased) requires a 10 AMP circuit, on the dedicated isolated ground panel

Lower Console Requirements

1. We need to run one cable from the bowler's console to the powerlift.
2. This cable is only ¼" in diameter however, the connector is almost 1" wide, and is considered low voltage cable. (5 Volts DC). It should be in a 1-1/2" conduit from the bowler console to the underground powerlift assembly.
3. Per the electrical code requirements in all states, we cannot install low voltage cable in an existing conduit if it contains high voltage from your tel-e-scores.