

US Steltronic, LLC

Electrical Requirements

The US Steltronic Automatic Scoring System consists of overhead and/or lower monitors at each pair of lanes and a Cash Control System at the Front Desk computer workstation. Each of these units contain computer components that require clean, dedicated, insulated, and isolated electrical circuits. The electrical requirements described in this document are essential to prevent electrical noise from entering the grounding circuit.

Warning: All electrical service must be installed by a licensed electrician and must meet all local and national electric codes. Failure to comply with the instructions contained in this document will void all hardware failure warranties due to electrical noise. If you need written certification that your electrical wiring meets these guidelines, you should have the installing licensed electrician provide the required documents. US Steltronic assumes no responsibility in determining the correctness of your electrical responsibilities.

US Steltronic, LLC is not responsible for damage or improper operation of The US Steltronic Automatic Scoring which is caused by improper installation or faulty electrical service. When installing the electrical service conduit, wiring and receptacles, the following guidelines must be strictly adhered to. Also see page Two (2)

- The Scoring System electrical panel must have its own separate *feeder* from the *main* service panel *or switch gear*. *No branch circuits other than Scoring System components are allowed within this panel.*
- The Scoring System electrical panel ground buss must be insulated from the panel enclosure. This ground buss should be grounded at the existing main service house ground bonding point. A separate ground rod is strongly discouraged.
- All plug-in receptacles must be isolated from the conduit. Conduit cannot be used as a ground.
- **EACH** circuit to the US Steltronic Automatic Scoring equipment must have a common insulated / isolated ground (no sharing of ground wires between circuits). Improper grounding, multiple grounds or grounding loops can cause erratic behavior and sometimes actual damage to the scoring equipment.
- **EACH** circuit to the US Steltronic Automatic Scoring equipment must have a common insulated / isolated Neutral (no sharing of neutral wires between circuits). Improper neutral, multiple neutral or neutral loops can cause erratic behavior and sometimes actual damage to the scoring equipment.
- In no instance may wires which supply power to the US Steltronic Automatic Scoring system share conduit with wires leading to any other equipment.
- Take extreme care to insure that the ground wire and neutral wires from the Scoring System Electrical Panel are not crossed. Voltage measured between the neutral and hot, ground and hot, or between the neutral and ground wires cannot differ more than 0.2 to 0.7 VAC. A higher differential may cause computer failure.

- Connect the Neutral and Ground at the Primary Service only. ALL circuits to The US Steltronic Automatic Scoring equipment must share a common ground. Improper grounding can cause erratic behavior and sometimes damage to the equipment. DO NOT connect equipment other than The US Steltronic Automatic Scoring to this panel or branch circuits.
- Use only Hubbell IG 5261 or IG 5262 receptacles (or equivalent).

Upon completion of wiring the Scoring System panel, the following procedure should be followed to insure there is no violation of the isolation of ground and neutral circuits. Test before any devices are plugged into any Scoring System I.G. receptacle.

- Disconnect the ground wire from the insulated ground buss that terminates at the house ground.
- Disconnect the neutral feed wire from the neutral buss.
- Check for continuity between the ground buss and the neutral buss - should read NO continuity.
- Check for continuity between the ground buss and the panel enclosure - should be NO continuity.
- Check for continuity between the neutral buss and the panel enclosure - should be NO continuity.
- Any circuit showing continuity should be physically checked for violation source and repaired.
- Upon passage of the above checks, reattach ground and neutral feeds.



Installing automatic scoring circuits in the same panel with other electrical circuits is NOT allowed and all warranties are VOID

A new "scoring only" panel should be installed and kept isolated from all other electrical

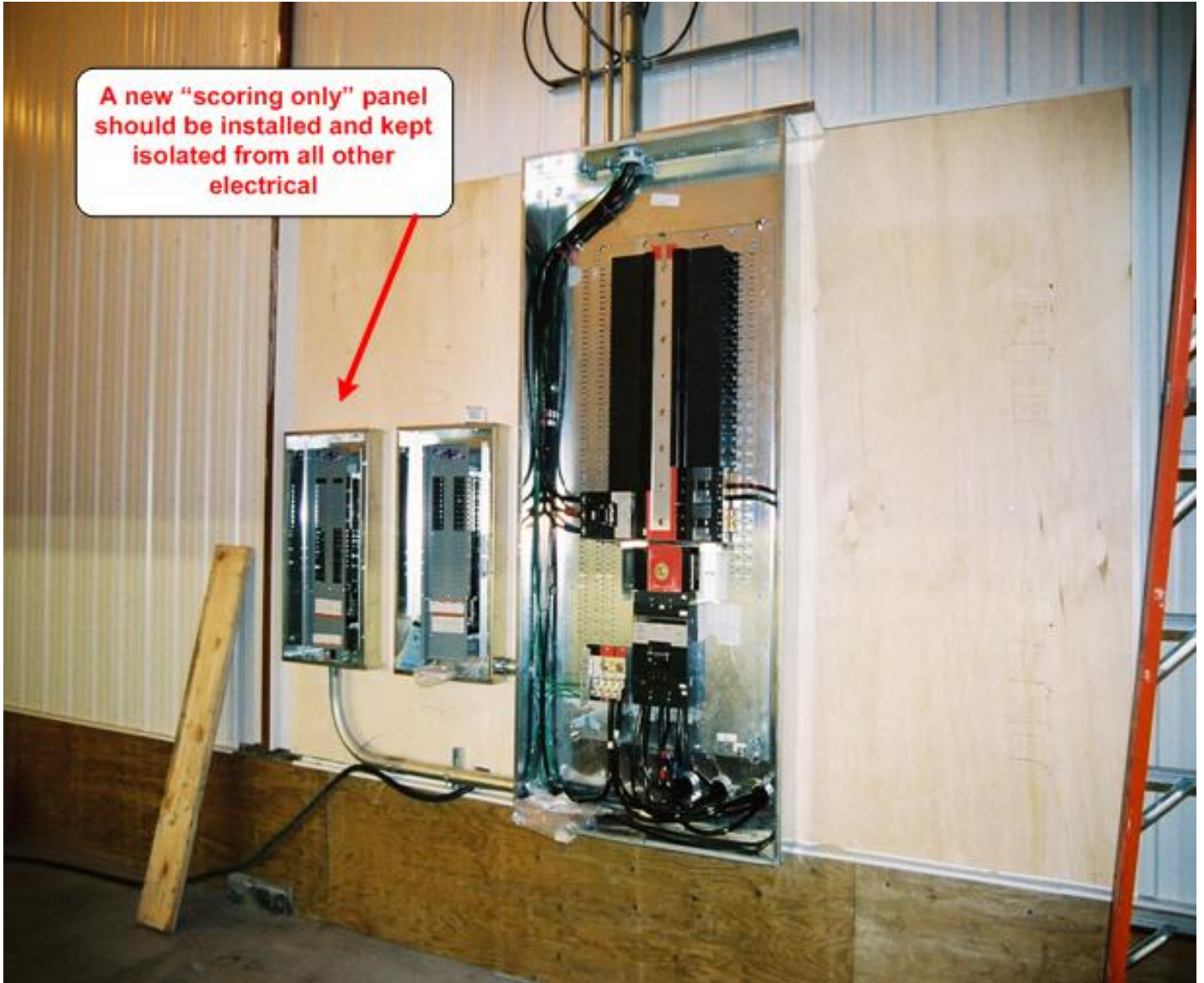

Sample configuration for 24 lanes with lane computers mounted near the monitors

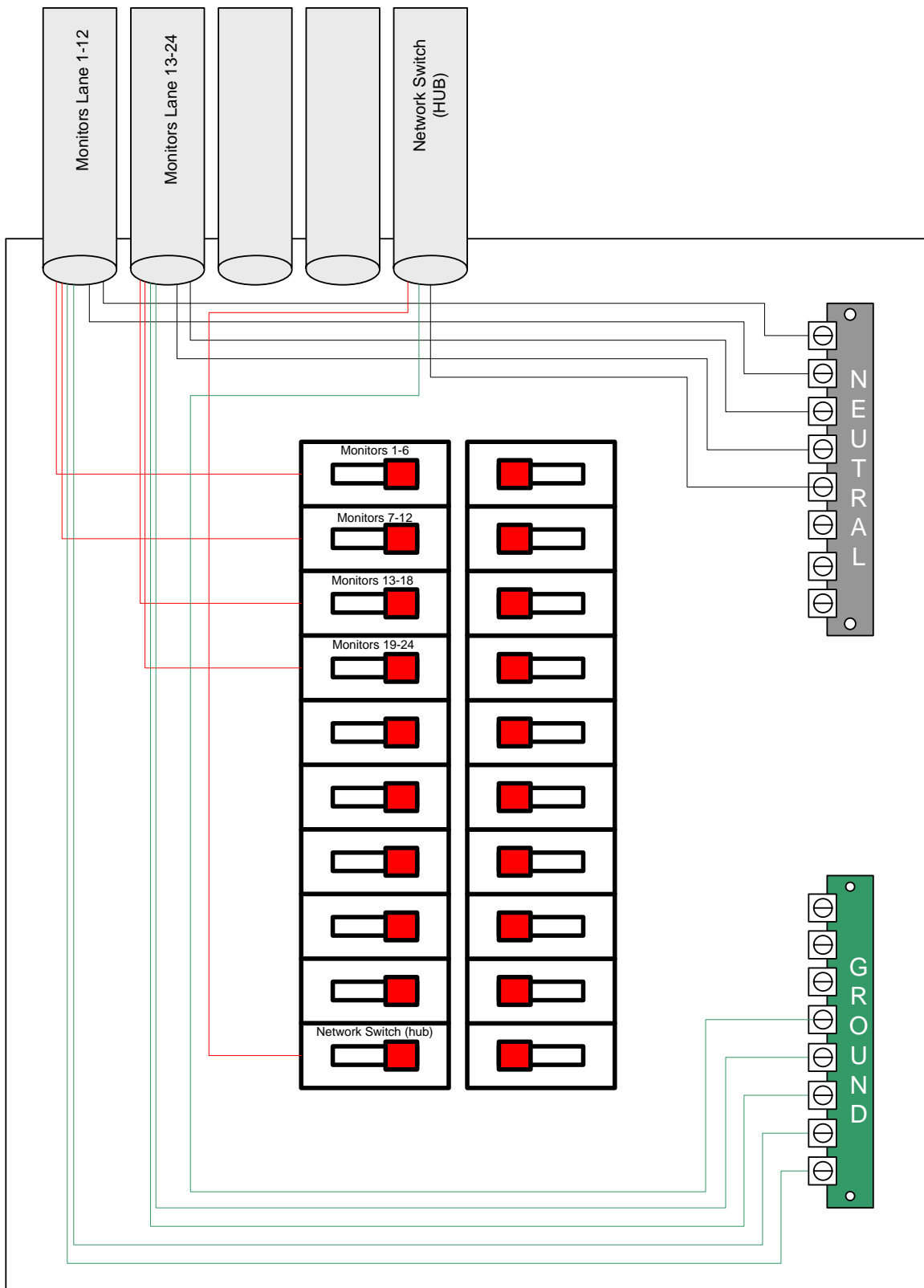

Sample configuration for 24 lanes with lane computers mounted on the curtain wall

